

Centac[®] C700

200-700 kW (300-900 hp)
Centrifugal Air Compressors

Ingersoll Rand Centac[®] centrifugal air compressors continue the tradition of simplicity by design with fewer parts and integrated components to take compressed air reliability, efficiency and productivity to even higher levels.



- **ISO Class 0 100% oil-free air** under all operating conditions. Certified by TÜV Rheinland[®].
- **Long-life Gears** are uniformly hardened and rated for 25 years to provide extreme reliability.
- **Backward Leaning Impellers** provide constant pressure control while maximising efficiency and turndown range.
- **Low Pressure Hydrodynamic Bearings** are completely non-contact, offering virtually unlimited life and minimal friction with 2-3 times the lifespan of traditional bearings.
- **Fully Floating, Non-Contact Carbon Ring Seals** minimise air leakage, prevent oil from migrating into the compressed air stream and provide significantly better performance than other technologies.

- **Vertical Split Casing** enables quick and easy access to main components.
- **Stainless Steel Moisture Separator** provides superior reliability and helps prevent corrosion, ensuring air quality.
- **Highly Efficient Coolers** maintain a low pressure drop and the large surface area provides maximum cooling efficiency. The integrated design reduces noise and results in a compact footprint.
- **Fully tested package** in accordance with ASME PTC 10.
- **Low installation, maintenance and operating costs.**



Xe-Series Controller

- **Advanced Xe-Series Controller** features an intuitive high resolution colour display with web-enabled communication and control.
- **History of reliability** with over 20,000 Ingersoll Rand Centac[®] centrifugal compressors in use worldwide.
- **Worldwide service** and parts support network.

Centac® C700

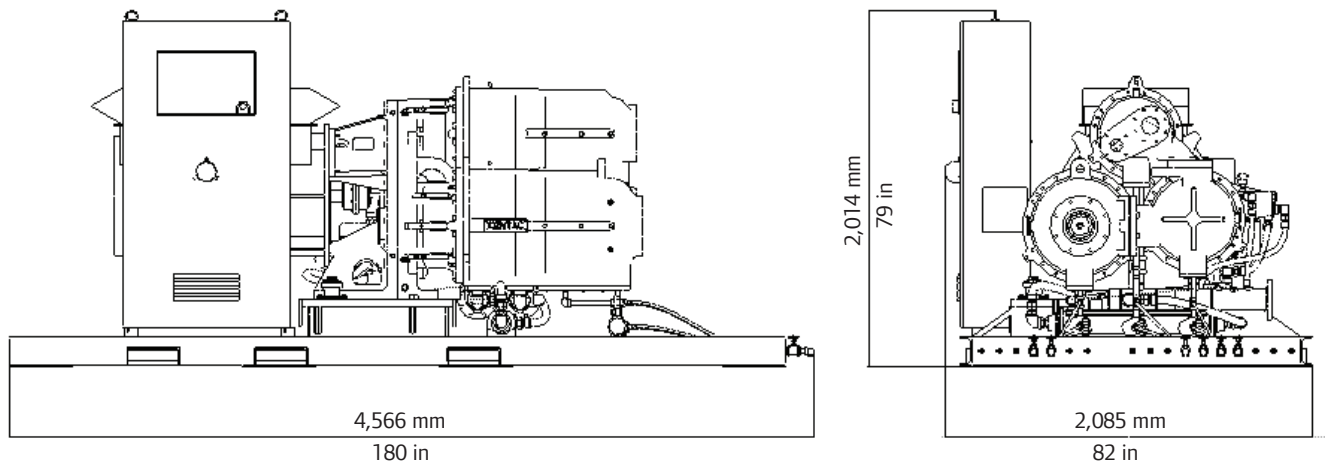

Standard Features Include:	
Complete tested package with built-in lubrication and cooling systems	High resolution, web-enabled controller
Inlet air filter and bypass silencer (shipped separately)	Auto-dual and constant pressure control
Built-in aftercooler	Remote communication and compressor control
Mounted discharge check valve	Stage data - pressure, temperature and vibration readout
Condensate traps, piped and mounted	Long life, Techtrol Gold compressor lubricant
Electrical control package	Certified ISO Class 0 oil-free air

Model	Nominal Capacity		Pressure		Power		Dimensions (Length x Width x Height)		Weight	
	m ³ /m	cfm	bar g	psig	kW	HP	mm	in	kg	lb
C700	54-119	1,900-4,200	3.1-10.3	45-150	200-700	300-900	2,995 x 1,953 x 1,869	118 x 77 x 73	9,550	21,000

Weights and dimensions are estimated and will vary with scope and options selected. Performance is nominal. Please contact Ingersoll Rand for specific data.



Ingersoll Rand, IR, the IR logo and Centac are trademarks of Ingersoll Rand, its subsidiaries and/or affiliates. All other trademarks are the property of their respective owners. Ingersoll Rand compressors are not designed, intended or approved for breathing air applications. Ingersoll Rand does not approve specialized equipment for breathing air applications and assumes no responsibility or liability for compressors used for breathing air service. Nothing contained on these pages is intended to extend any warranty or representation, expressed or implied, regarding the product described herein. Any such warranties or other terms and conditions of sale of products shall be in accordance with Ingersoll Rand's standard terms and conditions of sale for such products, which are available upon request. Product improvement is a continuing goal at Ingersoll Rand. Designs, available functions and specifications are subject to change without notice or obligation.

www.ingersollrandproducts.com